

Metric Conversions

MM x 0.03937 = Inches
 Inches x 25.4 = MM
 Grams x 0.03527 = Ounces
 Ounces x 28.349527 = Grams



Knurling Tools, Cut Type – Double Knurl

No. K1-219

**Diamond Pattern Cut Type
Knurling Tools**

An entry level cut type knurling tool for cutting 30° and 45° diamond patterns on Manual Lathes and CNC Turning Centers. Shanks are reversible to accommodate both Left hand and Right hand machines. Knurls are individually adjustable to insure a perfect tooth form and maximum tool life on any diameter within its capacity.

Features

- **Machine:** Manual, Automatic and CNC Lathes
- **Capacity:** see below
- **Knurl Sizes:** see below
- **Knurl Patterns:** Diamond 30 or 45°
(2 knurls AA or 1 knurl BL and 1 knurl BR 15°)
- **Knurls Included:** 1 set Medium pitch, Straight pattern (AA) knurls to produce a 30° Diamond pattern on your part.

Toolbox Basics™

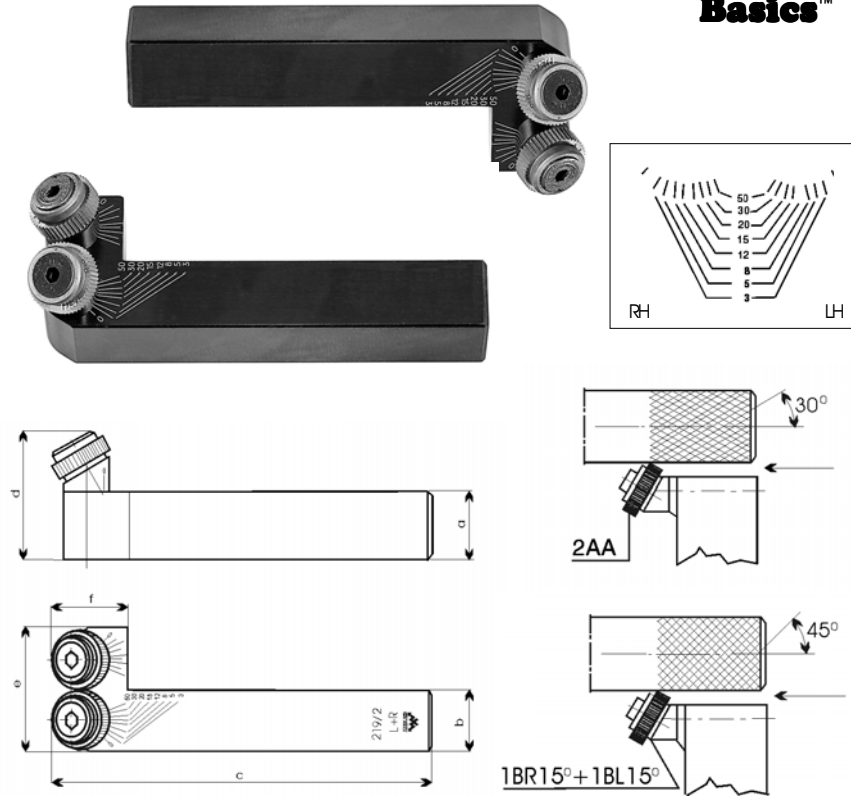

Capacity	a	b	c	d	e	f	Knurl Size	Cat. No.
2-15mm	11	10	82	24.5	20	15	AD -10x3x6	K1-219-M10U-AD
3-50	18	16	99	34	32	20	P -15x4x8	K1-219-M16U-P
10-250	20	20	125	44.50	53	30	V -25x6x8	K1-219-M20U-V

EAGLE ROCK TECHNOLOGIES INC. *Manufacturers of Specialty Tooling and Accessories since 1963*

One Eagle Rock Drive
 Bath, Pennsylvania
 18014-9648

1-610-759-5200 • Fax: 1-610-759-4340
 1-800-EAGLEROCK • 1-800-324-5376
www.EagleRockONLINE.com