

Metric Conversions

MM x 0.03937 = Inches
 Inches x 25.4 = MM
 Grams x 0.03527 = Ounces
 Ounces x 28.349527 = Grams



Knurling Tools, Cut Type – Double Knurl

No. K1-256

Diamond Pattern Cut Type Knurling Tools

An entry level cut type knurling tool for cutting 30° and 45° diamond patterns. Available with Manual (M20C-V) or reversible CNC (M20U-V) shanks to accommodate both Left hand and Right hand machines. Knurls are individually adjustable to insure a perfect tooth form and maximum tool life on any diameter within its capacity.

Features

- **Machine:** Manual or CNC Lathes
- **Capacity:** 10-250 mm (³/₈-10")
- **Knurl Sizes:** (V) 25x6x8
- **Knurl Patterns:** Diamond 30 or 45°
(2 knurls AA or 1 knurl BL and 1 knurl BR 15°)
- **Knurls Included:** 1 set Medium pitch, Straight pattern (AA) knurls to produce a 30° Diamond pattern on your part.

Toolbox Basics™

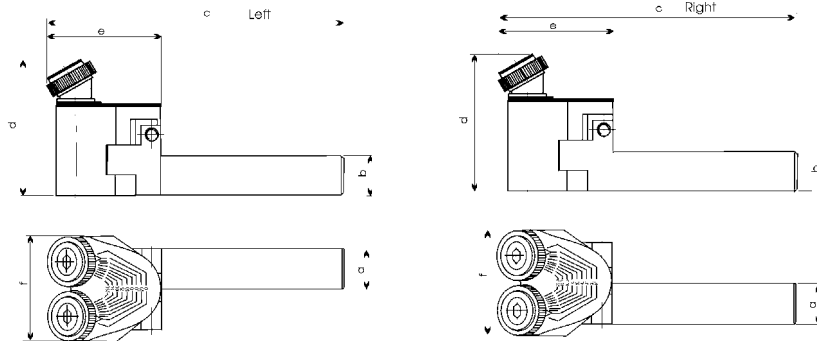

Capacity	a	b	c	d	e	f	Knurl Size	Cat. No.
10-250	20mm	20	138	70	58	58	V-25x6x8	K1-256-M20C-V
10-250	20mm	20	138	70	58	58	V-25x6x8	K1-256-M20U-V

EAGLE ROCK TECHNOLOGIES INC. *Manufacturers of Specialty Tooling and Accessories since 1963*
 One Eagle Rock Drive
 Bath, Pennsylvania
 18014-9648
 1-610-759-5200 • Fax: 1-610-759-4340
 1-800-EAGLEROCK • 1-800-324-5376
www.EagleRockONLINE.com