

**Metric Conversions**

MM x 0.03937 = Inches  
 Inches x 25.4 = MM  
 Grams x 0.03527 = Ounces  
 Ounces x 28.349527 = Grams



**Knurling Tools, Cut Type – Single Knurl**

**No. K1-259**

**Straight Pattern Cut Type  
Knurling Tool**

For CNC and conventional lathes.  
 Adjustable head for fine-tuning the  
 tooth form. Includes one Medium pitch, 30°  
 Diagonal (BL or BR) knurl to produce a  
 Straight pattern knurl on your part.

**Features**

- **Machine:** CNC Lathe
- **Knurl Size:** (V) 25x6x8
- **Knurl Patterns:** Straight (1 knurl BL or BR 30° as noted below)
- **Knurls Included:** 1 each Medium pitch, 30° Diagonal (BL or BR) knurl to produce a Straight pattern on your part.

**Toolbox  
Basics™**

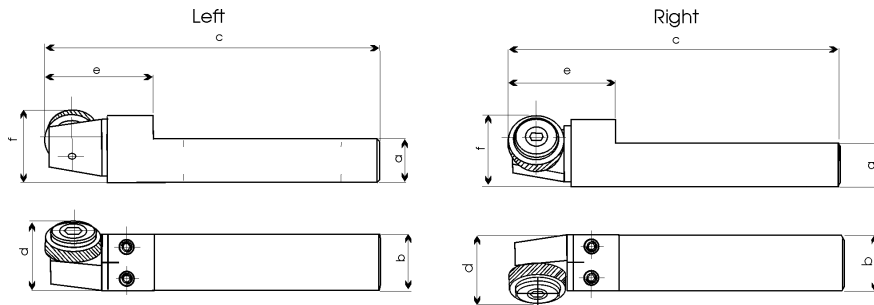

Capacity	a	b	c	d	e	f	Knurl Size	Cat. No.
10-300	20	25	129	31	49	32	V-25x6x8 BL 30	K1-259-M20L-V
10-300	20	25	129	31	49	32	V-25x6x8 BR 30	K1-259-M20R-V

**EAGLE ROCK TECHNOLOGIES INC.** *Manufacturers of Specialty Tooling and Accessories since 1963*

One Eagle Rock Drive  
 Bath, Pennsylvania  
 18014-9648

1-610-759-5200 • Fax: 1-610-759-4340  
 1-800-EAGLEROCK • 1-800-324-5376  
[www.EagleRockONLINE.com](http://www.EagleRockONLINE.com)