

Metric Conversions

MM x 0.03937 = Inches
 Inches x 25.4 = MM
 Grams x 0.03527 = Ounces
 Ounces x 28.349527 = Grams



Knurling Tools, Form Type – Double Knurl

No. K1-34

Clamp Style Knurling Tool

With shanks for CNC, Manual or Automatic Lathes. Compact design to fit into tight turret or work space configurations. Self-centering clamp type design absorbs all knurling pressures. Our exclusive one piece offset CNC shank insure maximum rigidity with virtually no X axis overhang. Includes one set of Medium pitch, Diamond pattern (BL and BR) knurls.

Features

- **Machine:** Manual, Automatic and CNC Lathes
- **Capacity:** 0-1³/₈"
- **Knurl Size:** (E) ³/₄x³/₈x¹/₄"
- **Knurl Patterns:** Straight (2 knurls AA) Diamond, Male (1 knurl BL, 1 knurl BR)
- **Knurls Included:** 1 set Medium pitch, Diamond (BL and BR) pattern

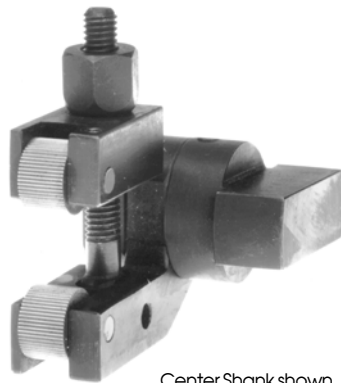

Center Shank shown

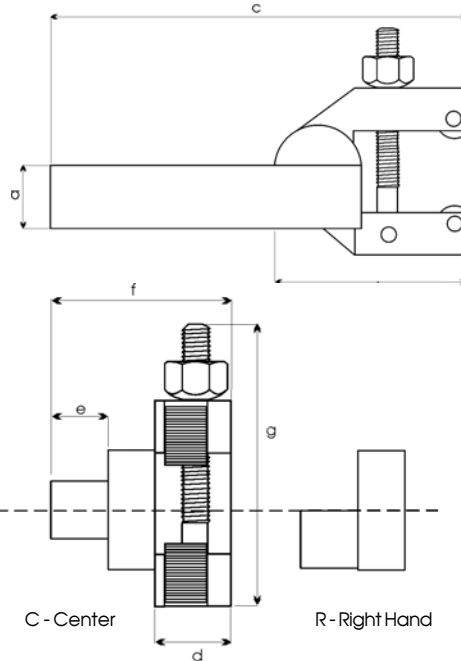

Shank Orientation

L - Left Hand

C - Center

R - Right Hand

a	b	c	d	e	f	g	Knurl Size	Cat. No.
1/2 R	3 3/8	6 7/8	1"	1"	3"	3 3/4	E- ³ / ₄ x ³ / ₈ x ¹ / ₄ "	K1-34-0500R-E
1/2 L	3 3/8	6 7/8	1	1	3	3 3/4	E- ³ / ₄ x ³ / ₈ x ¹ / ₄ "	K1-34-0500L-E
1/2 C	3 3/8	6 7/8	1	1	3	3 3/4	E- ³ / ₄ x ³ / ₈ x ¹ / ₄ "	K1-34-0500C-E
5/8 R	3 3/8	6 7/8	1	1	3	3 3/4	E- ³ / ₄ x ³ / ₈ x ¹ / ₄ "	K1-34-0625R-E
5/8 L	3 3/8	6 7/8	1	1	3	3 3/4	E- ³ / ₄ x ³ / ₈ x ¹ / ₄ "	K1-34-0625L-E
5/8 C	3 3/8	6 7/8	1	1	3	3 3/4	E- ³ / ₄ x ³ / ₈ x ¹ / ₄ "	K1-34-0625C-E
3/4 R	3 3/8	6 7/8	1	1	3	3 3/4	E- ³ / ₄ x ³ / ₈ x ¹ / ₄ "	K1-34-0750R-E
3/4 L	3 3/8	6 7/8	1	1	3	3 3/4	E- ³ / ₄ x ³ / ₈ x ¹ / ₄ "	K1-34-0750L-E
3/4 C	3 3/8	6 7/8	1	1	3	3 3/4	E- ³ / ₄ x ³ / ₈ x ¹ / ₄ "	K1-34-0750C-E
1" R	3 3/8	6 7/8	1	1	3	3 3/4	E- ³ / ₄ x ³ / ₈ x ¹ / ₄ "	K1-34-1000R-E
1" L	3 3/8	6 7/8	1	1	3	3 3/4	E- ³ / ₄ x ³ / ₈ x ¹ / ₄ "	K1-34-1000L-E
1" C	3 3/8	6 7/8	1	1	3	3 3/4	E- ³ / ₄ x ³ / ₈ x ¹ / ₄ "	K1-34-1000C-E

EAGLE ROCK TECHNOLOGIES INC. *Manufacturers of Specialty Tooling and Accessories since 1963*
 One Eagle Rock Drive
 Bath, Pennsylvania
 18014-9648
 1-610-759-5200 • Fax: 1-610-759-4340
 1-800-EAGLEROCK • 1-800-324-5376
 www.EagleRockONLINE.com