

Metric Conversions

MM x 0.03937 = Inches
 Inches x 25.4 = MM
 Grams x 0.03527 = Ounces
 Ounces x 28.349527 = Grams



Knurling Tools, Cut Type – Triple Knurl

No. K1-896

Turret Style Cut Type Knurling Tool

Three die turret type knurling tool with Synchronized adjustment. For diamond knurling on lathes and automatics without radial load. Jaws are reversible to accommodate a greater working range. Knurls are easily replaced for minimal downtime. Includes one set Medium pitch, Straight (AA) pattern knurls to produce a 30° Diamond pattern on your part.

Features

- **Machine:** Manual, Auto and CNC Lathes
- **Capacity:** see below
- **Knurl Size:** see below
- **Knurl Patterns:** 30° or 45° Diamond
- **Knurls Included:** 1 set Medium pitch, Straight pattern (AA) knurls to produce a 30° Diamond pattern on your part.

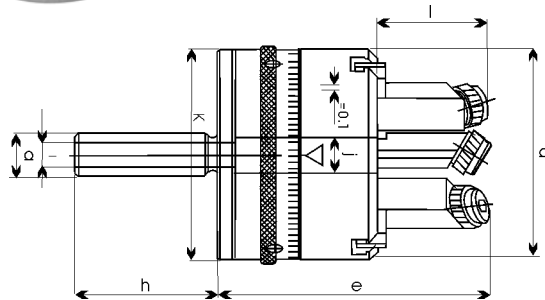

Capacity	a	d	e	h	i	j	k	l	Knurl Size	Cat. No.
3-15	12	46	46	40	9	11	46	14	AD-10x3x6	K1-896-M12D-AD
6-30	15	70	75	50	8.5	16	70	26		
25-55	15	70	74	50	8.5	16	70	25	P-15x4x8	K1-896-M15D-P
6-30	20	70	75	50	14	16	70	26		
25-55	20	70	74	50	14	16	70	25	P-15x4x8	K1-896-M20D-P



Manufacturers of Specialty Tooling and Accessories since 1963

One Eagle Rock Drive
 Bath, Pennsylvania
 18014-9648

1-610-759-5200 • Fax: 1-610-759-4340
 1-800-EAGLEROCK • 1-800-324-5376
www.EagleRockONLINE.com